

**ISLET CELL COUNTER
MODEL No: ICC-2**

USER MANUAL

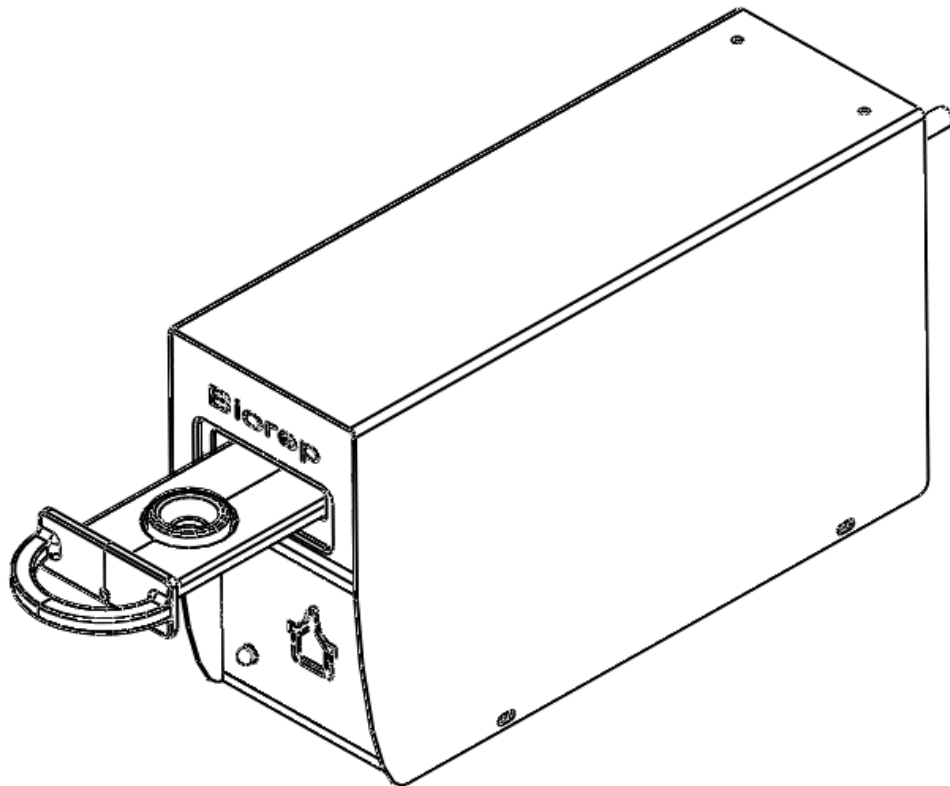

TABLE OF CONTENTS

1 GETTING STARTED..... 3

1.1 SYMBOLS USED IN THIS MANUAL 3

1.2 MACHINE INFORMATION 3

1.3 CONTACT INFORMATION 3

1.4 SAFETY INFORMATION 4

1.5 PACKING LIST 4

2 INTRODUCTION 5

3 MACHINE FEATURES IDENTIFICATION 6

4 ACCESSORIES..... 7

4.1 ISLET CELL COUNTER DISH (ICC-DISH) 7

5 SET-UP OF THE ICC..... 7

5.1 ICC CONNECTIONS..... 7

5.2 ISLET SAMPLE SETUP 7

5.3 SAMPLE STAINING..... 8

6 USING THE ICC..... 9

6.1 POWER UP..... 9

6.2 ICC GRAPHICAL USER INTERFACE (GUI) 9

6.2.1 *Display Panel*10

6.2.2 *Center Panel*.....10

6.2.3 *Control Panel*11

The control panel is where all the buttons and indicators required for performing a count are located. They are arranged in a top-down fashion, following the work-flow of the count:11

1. *Fill out the sample and user info*11

2. *Select if the sample is stained or not*.....11

3. *Acquire a video feed of the sample*11

And take a snapshot of your sample11

4. *Review the results of your count*.....11

5. *Generate a report*11

Start over. It's that simple. A more comprehensive review of the controls is described in the following section.....11

6.3 CONTROLS.....11

6.3.1 *Step 1. Enter sample information*11

6.3.2 *Step 2. Stained or Unstained*12

6.3.3 *Step 3. Image acquisition*.....12

6.3.4 *Step 4. Results*.....13

6.3.5 *Step 5. Report*14

7 CUSTOMER SERVICE15

1 Getting Started



1.1 Symbols Used in this Manual



The lightning flash with arrowhead symbol, within an equilateral triangle, is intended to alert the user to the presence of dangerous voltage within the machine's enclosure that may be of sufficient magnitude to constitute a risk of electric shock.



The exclamation point within an equilateral triangle is intended to alert the user to the presence of important information in the literature that accompanies the device.

1.2 Machine Information

In the spaces provided below, record the Model and Serial No. located on the rear panel of your machine.

Model No. _____

Serial No. _____

RETAIN THIS INFORMATION FOR FUTURE REFERENCE.

1.3 Contact Information

Biorep Technologies, Inc.

3225 NW 112th Street

Miami, FL 33167

info@biorep.com

www.biorep.com

Tel: 305-687-8074

Fax: 305-688-8029

1.4 Safety Information



PLEASE READ AND OBSERVE ALL WARNINGS AND INSTRUCTIONS GIVEN IN THIS USER'S MANUAL AND THOSE MARKED ON THE UNIT. RETAIN THIS BOOKLET FOR FUTURE REFERENCE.



DO NOT REMOVE THE MACHINE'S COVER OR YOU MAY BE EXPOSED TO DANGEROUS VOLTAGE. REFER SERVICING TO QUALIFIED PERSONNEL ONLY.



TO REDUCE THE RISK OF FIRE OR ELECTRIC SHOCK, DO NOT EXPOSE THIS DEVICE TO RAIN OR MOISTURE. DANGEROUS HIGH VOLTAGES ARE PRESENT INSIDE THE ENCLOSURE.

READ AND FOLLOW THESE INSTRUCTIONS:

1. Keep these instructions for future reference and heed all warnings stated in this manual.
2. Do not defeat the safety purpose of the polarized or grounding-type plug. A polarized plug has two blades with one wider than the other. A grounding-type plug has two blades and a third grounding prong, which is provided for your safety. If the provided plug does not fit into your outlet, consult an electrician for replacement of the obsolete outlet or contact Biorep Technologies, Inc. at (305) 687-8074.
3. Protect the power cord, the power entry module, and the plug from being walked on or pinched to avoid damaging them.
4. Refer all servicing of the machine to qualified personnel. Servicing is required when the apparatus has been damaged in any way.

1.5 Packing List

The following items are included with the purchase of an Islet Counter:

Qty	Reference	Description
1	ICC2	Islet counter vision system
1	LATITUDE-E5400	Islet counter Laptop
1	70913	4-6pos Fire-wire cable
1	86610610	Medical-Rated Cable (115 or 230 VAC)
1	ICC2-UM	User Manual
1	ICC-DISH	Islet Counter Dish pack (10)

Table 1: Packing List

2 Introduction

This User Manual is intended to be used by scientists, researchers, and technicians who have already been trained in islet isolation procedures and technologies. This document contains the necessary information for installing, and operating the islet counter vision system and its software.

The Islet Cell Counter (ICC) has been developed to assist in the estimation of Islet Equivalent counts (IEQ) from samples of isolated islet preparations. The islet counter is a useful tool to perform quantification of islet yield in islet isolations, or to quantify islet samples used for Perfusion experiments.

The islet counter was created to address the two main limitations of human counting: Speed and variability. Leveraging on machine vision technologies, the ICC can perform counts in seconds, yielding IEQ, area cover and purity (in stained mode) and allowing the generation of automatic reporting with the touch of a button. Trained human counters require several minutes to perform accurate counts and calculate and fill the required metrics for documentation. In addition, it is known that, despite standardization efforts, islet counts can vary dramatically from one human counter to the other. The adoption of machine vision technologies, reduces variability, and ensures that the same counting method is used every time. An ICC in your lab will count with the same method as any other ICC out there, making results more comparable and hopefully more significant.

Other software based cell counting technologies require training and rely significantly on user experience and input to perform accurate counts; therefore they are also subject to user variability. Furthermore, these software packages are independent of imaging hardware (such as microscopes, illumination and cameras), creating additional sources of variability.

The ICC is a self contained machine vision system, that includes both hardware and software designed specifically for islet counting. This ensures that magnification, field of view, illumination, focus, and other optical variables are constant, making the measurements repeatable and reliable across centers. The ICC software is powerful, yet its user interface is minimalist by design to facilitate an intuitive workflow. Ease of use was a top priority when developing the ICC technology. The ICC will generate the same count whether it is operated by the veterans or the rookies on the team.

3 Machine Features Identification

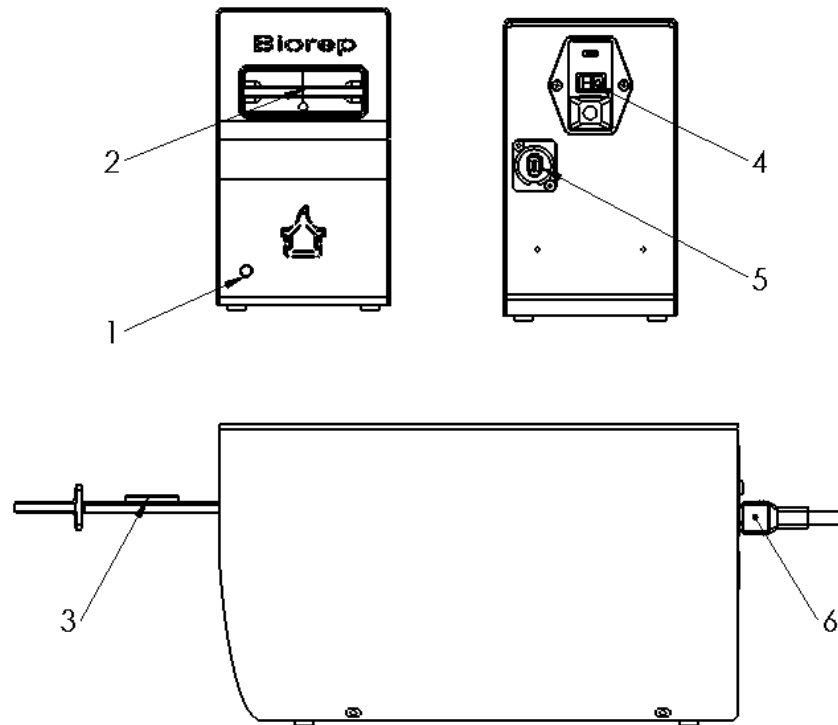

Figure 1: Islet Cell Counter Features

1. Power on indicator LED
2. Sample tray
3. ICC Dish nest
4. Power switch
5. Fire-wire connector
6. Power cable

4 Accessories

(Some of these items must be ordered separately. For ordering information please consult our webpage www.biorep.com or contact one of our sales representatives at 305-687-8074.)

4.1 Islet Cell Counter Dish (ICC-DISH)

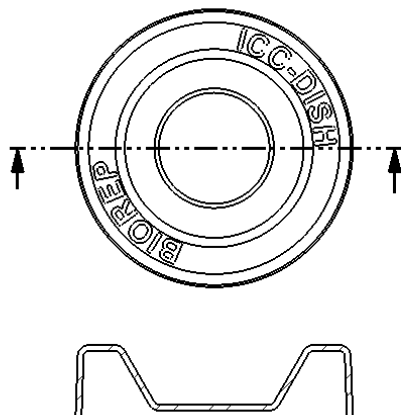

The ICC-Dish was specifically designed for use with the ICC. The central well is designed to provide enough area to allow the sample to be spread out to minimize errors due to aggregation, but it is compact enough to allow for high resolution imaging of the region of interest. The well is deep enough to minimize the risk of spillage during sampling and staining. The dish is accurately positioned with a matching nest geometry on the ICC tray.

Figure 2: Islet Cell Counter Dish (ICC-DISH)

5 Set-up of the ICC

5.1 ICC Connections

The ICC only requires 2 cables: Power and communications.

The power entry module, has an integrated power connector that accepts a standard hospital grade power cord (included). Make sure the small window on the power entry module displays the correct voltage rating for your area (115V or 230V).

The communications connection requires a 6-4pos fire-wire cable (included). The 6pos connector (large) is connected to the vision system and the 4pos connector (small) is connected to the fire-wire (1394) port on the laptop.

5.2 Islet Sample Setup

The sample to be counted must be pipetted into an ICC dish. The **recommended islet sample volume = 100 μ L** (this is the default value pre-filled on the sample information section)

To obtain accurate and repeatable results, please follow the following sample preparation requirements:

1. The bottom of the dish must be completely covered in fluid. Partial fluid coverage creates shadows at droplet boundaries that cause optical aberrations that will affect detection and count performance. The background of the image should be as uniform as possible. If counting stained preparations, add 250 μL of DTZ solution (See recommended DTZ solution preparation in the next section). If counting an unstained preparation, add 250 μL of buffer solution. A fill volume between 350 and 400 μL is recommended to ensure the dish surface is completely covered. Some slight leveling of the ICC-dish might be required to distribute the fluid uniformly.
2. Do not overfill the dish. Overfilling above 500 μL may have adverse effects on the illumination and the count accuracy.
3. Avoid air bubbles in the dish. Large air bubbles cause similar problems to those of partial fluid coverage. Small bubbles might cause localized errors and may even result in false positives.
4. The cell mass should be spread out as evenly as possible in the dish. Agglomeration makes software segmentation harder and the results less reliable. Gently shaking the dish, side to side, may help to distribute cells more evenly. (Swirling the dish in circles usually has the opposite effect and will tend to agglomerate the particles in the middle of the dish)
5. Cells should not be close to the edges of the dish. Although the vision system detects cells in most of the visible area, a small margin close to the edge is excluded to minimize the risk of artifact. Cells that are on or near the edge could get excluded from the count. The Region of Interest (ROI) which is the effective area where the software detects particles is shown as a “target” overlay when an image of the sample is acquired by the system.

5.3 Sample Staining

As with manual (human) counting, staining with dithizone (DTZ) drastically improves the count quality by creating contrast between acinar tissue and islets. The ICC allows the user to perform IEQ estimates of stained cell samples.

In isolation situations, a small aliquot is routinely sampled, stained and counted to estimate the total islet yield. Although the cells counted are no longer viable due to the DTZ stain, the tradeoff is a more accurate count, representative of the entire preparation.

As with any other parameter concerning machine vision, repeatability is the key factor. Staining with DTZ has to be done in a repeatable and controlled fashion. For best results, the DTZ formulation/composition, the amount of DTZ added to the dish, and the uptake time allowed for the islets to pick up the stain need to be consistent. We recommend the following best practices:

1. Dithizone (DTZ) Solution
 - a. Dissolve 100 mg Dithizone in 20 ml Dimethyl sulfoxide (DMSO) and mix
 - b. Add 30 ml HBSS
 - c. Filter using a 0.2 or 0.4 μm bottle top filter
 - d. Add 50 ml HBSS
 - e. Label appropriately and use on the day of preparation
 - f. Store at room temperature (20-28°C).

2. DTZ amount should be 250 μL on 100 μL of cell sample volume.
3. **Uptake time should be at least 8 minutes before performing a count. The value of the count may change as the cells get stained if counted prematurely. An alternate approach is to perform a series of counts every minute until two consecutive counts remain constant or within a small percentage of each other.**

6 Using the ICC

6.1 Power Up

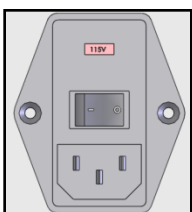

The machine's main power switch and fuse are located on the back of the machine. Connect the power cord (provided in the accessory box) to the module, plug it into a 115 VAC (230 VAC) outlet.

Figure 1: Power Module

Make sure the fire-wire cable is connected to both the laptop and the vision system. Power up the ICC laptop. Boot into windows and double click on the ICC icon on the desktop.

6.2 ICC Graphical User Interface (GUI)



Figure 2: User Interface

This is the one and only screen you will encounter when using the ICC. Here you will be able to enter the relevant information about the sample, activate the vision system, perform a count and generate a report. The interface is designed to facilitate the workflow in a numbered, step-by-step fashion.

6.2.1 Display Panel

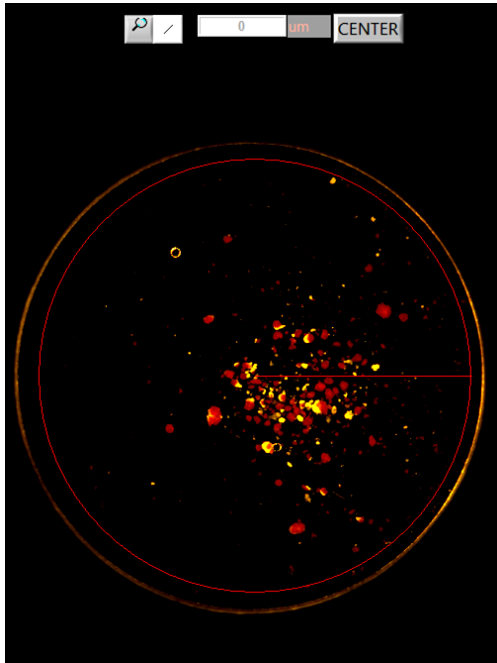

The Display Area shows all images and auxiliary overlays from the vision system. Use this display to check that your sample is properly stained (if applicable), and within the boundaries of the region of interest (ROI), delimited by the target overlay. Only the cells within this target will be counted.

There are a few controls at the top of the panel that allow for basic inspection of the sample:

The loupe icon will enable zooming into the image. You can zoom in by clicking on the image, and zoom out with SHIFT+click. If you wish to return to full screen view, press the CENTER button.

The line icon will activate the measure tool. You can make linear measurements on the image by clicking on the start and end point of the dimension you are looking for. A line will be drawn and the measurement will be displayed in micrometers on the adjacent field.

6.2.2 Center Panel

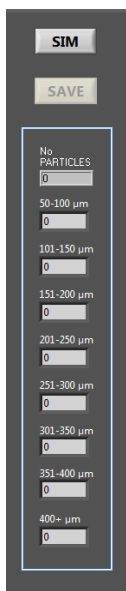

The center panel can be divided in two independent groups: The imaging archive controls, and the islet size distribution table.

The two buttons at the top are the archiving controls. If you want to save a full resolution image of your sample for future reference, press the SAVE button before pressing SNAPSHOT. When SNAPSHOT is pressed a dialog box will appear that will prompt you to give a name to the image. The image will be saved on the ICC2/SAMPLES folder.

The SIM button allows the machine to simulate acquisitions from previously saved images for purposes of training or inspection. Before pressing the ACQUIRE button, press the SIM button. When ACQUIRE is pressed, a dialog will appear, allowing you to select one of the images from your IMAGES folder. When selected, the image will appear on the Display Panel as if it was being acquired from the vision system.

The other group of indicators relates to islet size groups. After a count is performed, this table will show an approximation of the amount of particles assigned to each IEQ size group. It will also show the total number of particles detected. A graphical representation of these numbers will be generated with the automated excel report.

6.2.3 Control Panel



The control panel is divided into five numbered sections:

- 1** Input fields for USER ID, SAMPLE ID, NOTES, COUNT No, PURITY STAGE/LAYER, SAMPLE VOLUME (µL) (pre-filled with 100), and TOTAL VOLUME (mL). A CLEAR FIELDS button is located at the bottom right of this section.
- 2** Two buttons: STAINED and UNSTAINED.
- 3** Two buttons: ACQUIRE and SNAPSHOT.
- 4** A DILUTION FACTOR input field (pre-filled with 0) and an IEQ button. Below this are three input fields: AREA (0 mm²), PURITY (0 %), and Q.I. (0).
- 5** Two buttons: REPORT and RESET.

The control panel is where all the buttons and indicators required for performing a count are located. They are arranged in a top-down fashion, following the work-flow of the count:

1. Fill out the sample and user info
2. Select if the sample is stained or not
3. Acquire a video feed of the sample
And take a snapshot of your sample
4. Review the results of your count
5. Generate a report

Start over. It's that simple. A more comprehensive review of the controls is described in the following section.

6.3 Controls

6.3.1 Step 1. Enter sample information

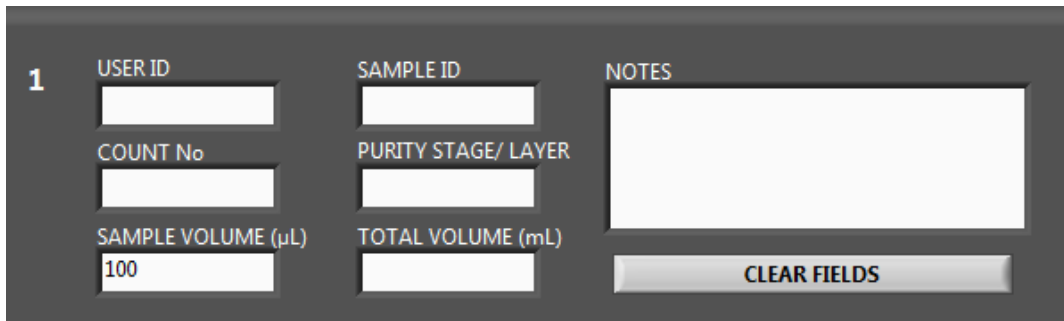

This section, labeled '1', contains the following input fields and a button:

- USER ID
- SAMPLE ID
- NOTES
- COUNT No
- PURITY STAGE/ LAYER
- SAMPLE VOLUME (µL) (pre-filled with 100)
- TOTAL VOLUME (mL)
- CLEAR FIELDS button

The first step on every count will be to enter the count information. This is relevant if you intend to generate a report after the count is performed.

- The USER ID should be the name or some type of ID for the ICC user.
- The SAMPLE ID should be filled with any reference number given to the sample, be it a patient number, organ number or experiment number.
- The COUNT No. is there to keep a record of consecutive counts of the same sample
- PURITY STAGE/LAYER refers to the stage during the preparation where the sample was taken
- SAMPLE VOLUME is measured in micro-liters, and is pre-filled with 100µl, which is the recommended sample volume.
- TOTAL VOLUME refers to the volume of the preparation from where the sample was taken. The proportion between SAMPLE VOLUME and TOTAL VOLUME will determine

the dilution factor (which is automatically calculated). The resulting IEQ will be the product of the IEQ in the dish and the dilution factor.

- The NOTES section is provided for any other information you want recorded in the report.
- The CLEAR FIELDS button will do exactly that.

6.3.2 Step 2. Stained or Unstained



The second step is to select whether you will be counting a stained or an unstained sample. The algorithms for detecting stained and unstained preparation are different, so selecting the correct staining state is fundamental for generating an accurate count. You can switch between the two options before pressing ACQUIRE.

NOTE: The UNSTAINED mode will **NOT** yield an IEQ estimate. The results in this mode are limited to particle count, size grouping and area cover. IEQ will be displayed as **NaN** (Not a Number). The **Purity** and **Q.I.** parameters will also be unavailable since they depend on the staining to work.

6.3.3 Step 3. Image acquisition



The Acquire button activates the vision system. A live video feed of the sample will appear on the screen. Here you can check the sample for proper staining, bubbles and islet aggregation.

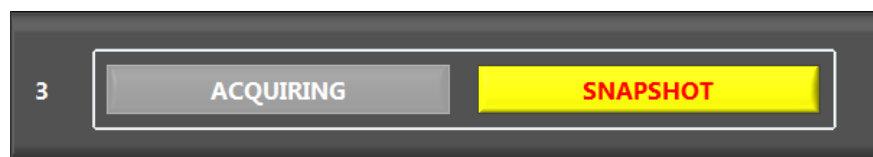

When ready to count, press the SNAPSHOT button. This button will acquire a high resolution image of the sample and will immediately proceed to detect, segment and perform quantification operations on the sample. The results will be displayed as soon as they are calculated.

6.3.4 Step 4. Results

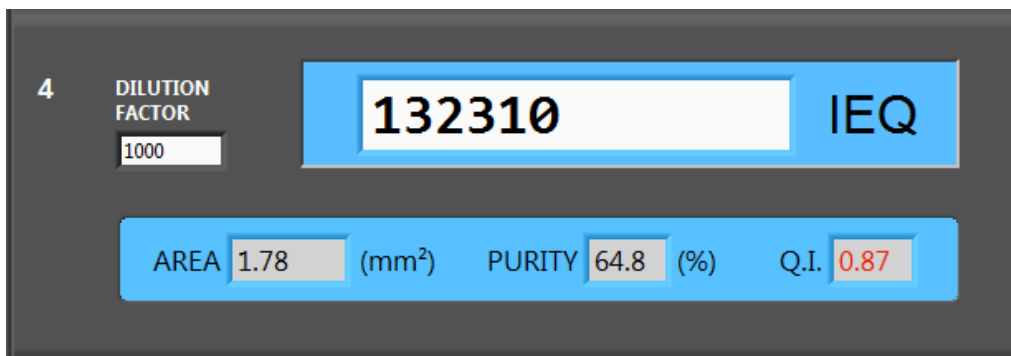
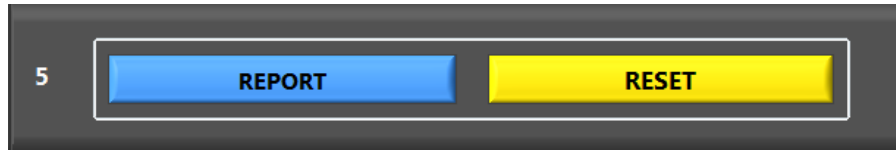

Figure 9. Results Panel

The results panel displays the main count information:

- **DILUTION FACTOR** is displayed as calculated from the information fields in step 1. This field can be over-ridden by simply typing a new number and pressing enter. A dilution factor of one (1) will yield the IEQ content in the ICC-dish.
- **IEQ** displays the total islet equivalent in the preparation as calculated from the sample contents and the dilution factor. (Only available in STAINED mode)
- **AREA** provides the islet area cover in millimeters squared. This is thought to provide a very consistent metric of islet quantity, which is not subject to size weightings like IEQ, and is less sensitive to cell aggregation.
- **PURITY** provides a ratio between the area covered by islets and the total area covered by tissue in the sample (Only available in STAINED mode)
- **Q.I.** is an experimental count quality index, which correlates area cover to IEQ. One of the challenges of accurate counting is related to sampling variability. It is known that the predominance of large islets in a preparation can lead to significant variability of counts within the same preparation. The presence or absence of a single large (> 400µm diameter) islet cell can vary the IEQ count of a 100 microliter sample by a significant amount (~16,000 IEQ with a 1000 dilution factor). The Q.I. gives the user an idea of the impact of large (or small) islets on the IEQ value. This is done by working backwards from the area. Assuming the entire covered area is made up by ideal islets of one (1) IEQ each (150µm diameter), an “idealized” **Area-Based-IEQ** can be obtained. The proportion between the Size group based IEQ (the one displayed on the results) and this idealized Area-Based-IEQ will provide a qualitative indicator of the effect of large or small particles in the count. If there are many large particles, the idealized Area-Based-IEQ will be lower than the Results IEQ count; Thus the Q.I. will be less than 1. If small islets are prevalent, the Q.I. will be larger than 1. It is up to the researcher to use and determine any acceptance criteria based on the Q.I. The Q.I. is an experimental parameter which has not been validated in the field, but was included in the ICC2 software to assess its value in addressing the sampling variability problem. Any feedback on this feature is greatly appreciated.

6.3.5 Step 5. Report



Here you have the option to generate a report or start over. To start over, just press the RESET button. Pressing the REPORT button will automatically generate an Excel report of the count with all the information, results and relevant count statistics.

Minimize the ICC2 window to see the report.

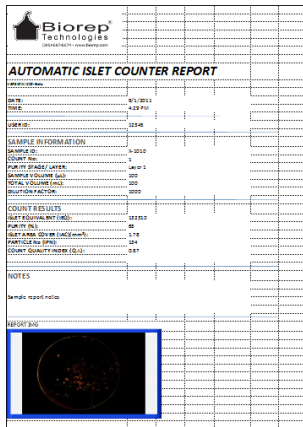

The report is 2 pages long. The first page contains the time and date of the count and all the data related to the user and sample.

It will also contain the numerical values of the results, including Dilution factor, IEQ, Purity and Q.I.

The 1st page will also have a small snapshot of the sample and display any notes written on the available files

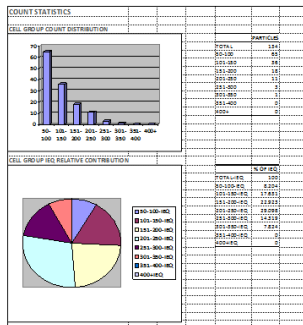

The Second page of the report contains graphical visualizations of the results. The first graph, represented by a bar graph shows the numerical quantity of particles in each size group. Generally speaking, the quantity is inversely proportional to the size group. The smaller the islets, the more there are of them.

The second chart, represented by a pie chart, shows how much of the total IEQ is contributed by each size group. With this representation it can be seen that despite the big difference in numerical particle quantities, the contribution of each size group to IEQ is generally more uniform.



7 Customer Service

If you encounter any problems, please contact customer support at:

Biorep Technologies, Inc.

3225 NW 112th Street

Miami, FL 33167

info@biorep.com

www.biorep.com

Tel: 305-687-8074

Fax: 305-688-8029